



ASSOCIATION CONNECTING
ELECTRONICS INDUSTRIES®

IPC-7711A/7721A

Rework of Electronic Assemblies

IPC-7711, Change 1 - February 2002

IPC-7711 - February 1998

Repair and Modification of Printed Boards and Electronic Assemblies

IPC-7721, Change 2 - April 2001

IPC-7721, Change 1 - March 2000

IPC-7721 - February 1998

These standards are now published in a single volume with three sections. Part 1 includes the general information and procedures that are common to both IPC-7711A and IPC-7721A. Part 2 includes all the rework procedures from IPC-7711A and Part 3 includes all the repair and modification procedures from IPC-7721A.

Developed by the Repairability Subcommittee (7-34) of the Product Assurance Committee (7-30) of IPC

Supersedes:
IPC-R-700C - January 1988

Users of this publication are encouraged to participate in the development of future revisions.

Contact:



IPC
2215 Sanders Road
Northbrook, Illinois
60062-6135
Tel 847 509.9700
Fax 847 509.9798

Table of Contents





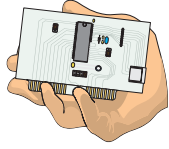

PART 1 General Information and Common Procedures

1 General	1	4. Procedure Selection	4
1.1 Scope	1	5. Patience	4
1.2 Purpose	1	6. Heat Application	4
1.2.1 Definition of Requirements	1	7. Removal of Coatings	4
1.2.2 Requirements Flowdown	1	1.8 Tools and Materials	4
1.3 Background	1	1. Proper Workstations	4
1.4 Controls	1	2. High Quality Microscope	4
1. Modification	1	3. Lighting	4
2. Rework	1	4. Soldering Tools	4
3. Repair	1	5. Component Removal and Installation	4
1.4.1 Classification	2	6. Preheating (Auxiliary) Heating	4
1. Class 1 – General Electronics Products	2	7. Fume Extraction	4
2. Class 2 – Dedicated Service Electronic Products	2	8. Hand Held Drilling and Grinding Tool	4
3. Class 3 – High Performance Electronic Products	2	9. Precision Drill/Mill System	5
1.4.2 Printed Board Types	2	10. Replacement Conductors and Lands	5
R. Rigid Printed Boards and Assemblies	2	11. Gold Plating System	5
F. Flexible Printed Boards and Assemblies	2	12. Epoxy and Coloring Agents	5
W. Discrete Wiring Boards and Assemblies	2	13. Eyelets and Eyelet Press System	5
C. Ceramic Boards and Assemblies	2	14. Cleaning Station/System	5
1.4.3 Level of Conformance	2	15. Tools and Supplies	5
1.4.4 Levels of Conformance	2	16. Conformal Coating Area	5
L. Lowest Level	2	17. Materials	5
M. Medium Level	2	1.9 Process Goals and Guidelines	5
H. Highest Level	2	1.9.1 Non-destructive Component Removal	6
1.4.5 Skill Level	3	1.9.2 Surface Mount Land Preparation	6
1.5 Terms and Definitions	3	1. Remove Old Solder	6
1.6 Training	3	2. Clean Lands	6
1. Soldering Skills	3	1.9.3 Component Installation	6
2. Personnel Selection	3	1.9.4 Primary Heating Methods	7
3. Professional Training	3	1.9.5 Preheating and Auxiliary Heating Methods	8
1.7 Basic Considerations	4	1.9.6 Vision Systems and Surface Mount Component Placement	8
1. Appropriate Approvals	4	1.9.7 Selecting Optimum Process for Manual Assembly/Rework	9
2. Singular Procedures	4	1.9.8 BGA/CSP/Flip Chip Time Temperature Profile (TTP)	9
3. Quality and Reliability	4	1.9.9 Lead Free Solder	9



Handling/Cleaning

Procedure	Description	Illustration	Product Class	Skill Level	Level of Conformance
2.1A	Handling Electronic Assemblies		R,F,W,C	Intermediate	High
2.2	Cleaning		R, F, C, W	Intermediate	High

Coating Removal

Procedure	Description	Illustration	Product Class	Skill Level	Level of Conformance
2.3.1	Coating Removal, Identification of Conformal Coating		R, F, W, C	Advanced	High
2.3.2	Coating Removal, Solvent Method		R, F, W, C	Advanced	High
2.3.3	Coating Removal, Peeling Method		R, F, W, C	Advanced	High
2.3.4	Coating Removal, Thermal Method		R, F, W, C	Advanced	High
2.3.5	Coating Removal, Grinding/Scraping Method		R, F, W, C	Advanced	High
2.3.6	Coating Removal, Micro Blasting Method		R, F, W, C	Advanced	High

Coating Replacement

Procedure	Description	Illustration	Product Class	Skill Level	Level of Conformance
2.4.1	Coating Replacement, Solder Resist		R, F, W, C	Intermediate	High
2.4.2	Coating Replacement, Conformal Coatings/Encapsulants		R, F, W, C	Intermediate	High

Conditioning

Procedure	Description	Illustration	Product Class	Skill Level	Level of Conformance
2.5	Baking and Preheating		R, F, W, C	Intermediate	High

Epoxy Mixing and Handling

Procedure	Description	Illustration	Product Class	Skill Level	Level of Conformance
2.6	Epoxy Mixing and Handling		R, F, W, C	Intermediate	High

Table of Contents

PART 2 Rework of Electronic Assemblies

3 Removal

3.1 Through-Hole Removal

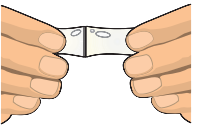
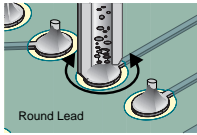
Procedure	Description		Product Class	Skill Level	Level of Conformance
3.1.1A	Continuous Vacuum Method		R,F,W	Intermediate	High
3.1.2	Continuous Vacuum Method - Partial Clinch		R,F,W	Intermediate	High
3.1.3	Continuous Vacuum Method - Full Clinch		R,F,W	Intermediate	High
3.1.4	Full Clinch Straightening Method		R,F,W	Intermediate	High
3.1.5	Full Clinch Wicking Method		R,F,W	Advanced	High

3.2 PGA and Connector Removal

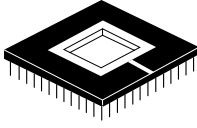
Procedure	Description		Product Class	Skill Level	Level of Conformance
3.2.1	Solder Fountain Method		R,F,W,C	Expert	Medium

3.3 Chip Component Removal

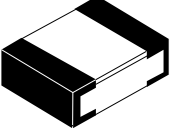
Procedure	Description		Product Class	Skill Level	Level of Conformance
3.3.1	Bifurcated tip		R,F,W,C	Intermediate	High
3.3.2	Tweezer Method		R,F,W,C	Intermediate	High
3.3.3	Bottom Termination - Hot Air Method		R,F,W,C	Intermediate	High

3.4 Leadless Component Removal

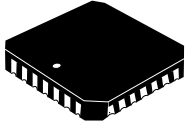
Procedure	Description		Product Class	Skill Level	Level of Conformance
3.4.1	Solder Wrap Method		R,F,W,C	Advanced	High
3.4.2	Flux Application Method		R,F,W,C	Advanced	High

3.5 SOT Removal

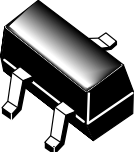
Procedure	Description		Product Class	Skill Level	Level of Conformance
3.5.1A	Flux Application Method		R,F,W,C	Intermediate	High
3.5.2A	Flux Application Method - Tweezer		R,F,W,C	Intermediate	High
3.5.3A	Hot Air Pencil		R,F,W,C	Intermediate	High

3.6 Gull Wing Removal (two sided)

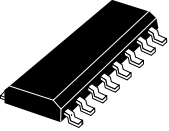
Procedure	Description		Product Class	Skill Level	Level of Conformance
3.6.1	Bridge Fill Method		R,F,W,C	Intermediate	High
3.6.2A	Solder Wrap Method		R,F,W,C	Intermediate	High
3.6.3	Flux Application Method		R,F,W,C	Intermediate	High
3.6.4A	Bridge Fill Method - Tweezer		R,F,W,C	Advanced	High
3.6.5A	Solder Wrap Method - Tweezer		R,F,W,C	Advanced	High
3.6.6A	Flux Application Method - Tweezer		R,F,W,C	Advanced	High

3.7 Gull Wing Removal (four sided)

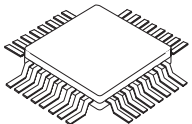
Procedure	Description		Product Class	Skill Level	Level of Conformance
3.7.1A	Bridge Fill Method - Vacuum Cup		R,F,W,C	Advanced	High
3.7.1.1	Bridge Fill Method - Surface Tension		R,F,W,C	Intermediate	High
3.7.2A	Solder Wrap Method - Vacuum Cup		R,F,W,C	Advanced	High
3.7.2.1	Solder Wrap Method - Surface Tension		R,F,W,C	Intermediate	High
3.7.3	Flux Application Method - Vacuum Cup		R,F,W,C	Advanced	High
3.7.3.1	Flux Application Method - Surface Tension		R,F,W,C	Intermediate	High
3.7.4A	Bridge Fill Method - Tweezer		R,F,W,C	Advanced	High
3.7.5A	Solder Wrap Method - Tweezer		R,F,W,C	Advanced	High
3.7.6	Flux Application Method - Tweezer		R,F,W,C	Advanced	High
3.7.7	Hot Gas Reflow Method		R,F,W,C	Advanced	High

3.8 J-Lead Removal

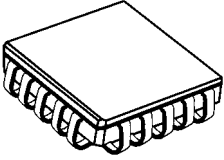
Procedure	Description		Product Class	Skill Level	Level of Conformance
3.8.1	Bridge Fill Method - Tweezer		R,F,W,C	Advanced	High
3.8.1.1	Bridge Fill Method - Surface Tension		R,F,W,C	Advanced	High
3.8.2	Solder Wrap Method - Tweezer		R,F,W,C	Advanced	High
3.8.2.1	Solder Wrap Method - Surface Tension		R,F,W,C	Advanced	High
3.8.3	Flux Application Method - Tweezer		R,F,W,C	Advanced	High
3.8.4	Flux & Tin Tip Only		R,F,W,C	Advanced	High
3.8.5	Hot Gas Reflow System		R,F,W,C	Advanced	High

3.9 BGA/CSP Removal

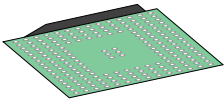
Procedure	Description		Product Class	Skill Level	Level of Conformance
3.9.1	BGA/CSP Removal		R,F,W,C	Advanced	High
3.9.2	Vacuum Method		R,F,W,C	Advanced	Medium

3.10 PLCC Socket Removal

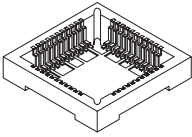
Procedure	Description		Product Class	Skill Level	Level of Conformance
3.10.1	Bridge Fill Method		R,F,W,C	Advanced	High
3.10.2	Solder Wrap Method		R,F,W,C	Advanced	High
3.10.3	Flux Application Method		R,F,W,C	Advanced	High
3.10.4	Hot Air Pencil Method		R,F,W,C	Advanced	Medium

4 Pad/Land Preparation

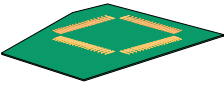
Procedure	Description		Product Class	Skill Level	Level of Conformance
4.1.1	Surface Mount Land Preparation - Individual Method		R,F,W,C	Intermediate	High
4.1.2	Surface Mount Land Preparation - Continuous Method		R,F,W,C	Intermediate	High
4.1.3	Surface Solder Removal - Braid Method		R,F,W,C	Intermediate	
4.2.1	Pad Releveling		R,F,W,C	Intermediate	Medium
4.3.1	SMT Land Tinning		R,F,W,C	Intermediate	Medium
4.4.1	Cleaning SMT Lands		R,F,W,C	Intermediate	High

5 Installation

5.1 Through-Hole Installation

Procedure	Description	
	Install following the requirements of J-STD-001 and J-HDBK-001	

5.2 PGA and Connector Installation

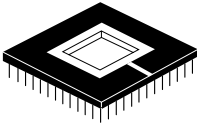
Procedure	Description		Product Class	Skill Level	Level of Conformance
5.2.1	Solder Fountain Method with PTH Prefilled		R,F,W,C	Expert	Medium

5.3 Chip Installation

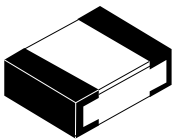
Procedure	Description		Product Class	Skill Level	Level of Conformance
5.3.1	Solder Paste Method		R,F,W,C	Intermediate	High
5.3.2	Point to Point Method		R,F,W,C	Intermediate	High

5.4 Leadless Component Installation (To Be Developed)

5.5 Gull Wing Installation

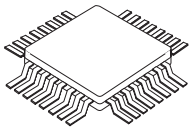
Procedure	Description		Product Class	Skill Level	Level of Conformance
5.5.1A	Multi-Lead Method - Top of Lead		R,F,W,C	Advanced	High
5.5.2	Multi-Lead Method - Toe Tip		R,F,W,C	Advanced	High
5.5.3	Point-to-Point Method		R,F,W,C	Intermediate	High
5.5.4	Hot Air Pencil/Solder Paste Method		R,F,W,C	Advanced	High
5.5.5	Hook Tip w/Wire Layover (To be developed)		R,F,W,C	Intermediate	High
5.5.6	Blade Tip with Wire		R,F,W,C	Advanced	High

5.6 J-Lead Installation

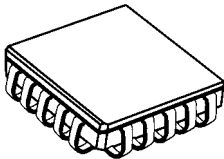
Procedure	Description		Product Class	Skill Level	Level of Conformance
5.6.1	Wire Solder Method		R,F,W,C	Advanced	High
5.6.2	Point-to-Point Method		R,F,W,C	Intermediate	High
5.6.3	Solder Paste Method/Hot Air Pencil		R,F,W,C	Advanced	High
5.6.4	Multi-Lead Method		R,F,W,C	Intermediate	High

5.7 BGA/CSP Installation

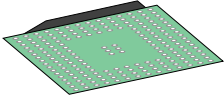
Procedure	Description		Product Class	Skill Level	Level of Conformance
5.7.1	Using Wire Solder to Prefill Lands		R,F,W,C	Advanced	High
5.7.2	Using Solder Paste to Prefill Lands		R,F,W,C	Advanced	High
5.7.3	BGA Reballing Procedure		R,C	Advanced	High

6 Removing Shorts

Procedure	Description		Product Class	Skill Level	Level of Conformance
6.1.1	J-Leads - Draw Off Method		R,F,W,C	Intermediate	High
6.1.2	J-Leads - Respread Method		R,F,W,C	Intermediate	High
6.1.3	Gull-Wing - Draw Off Method		R,F,W,C	Intermediate	High
6.1.4	Gull-Wing - Respread Method		R,F,W,C	Intermediate	High

8 Wires**8.1 Splicing**





Procedure	Description		Product Class	Skill Level	Level of Conformance
8.1.1	Mesh Splice		N/A	Intermediate	Low
8.1.2	Wrap Splice		N/A	Intermediate	Low
8.1.3	Hook Splice		N/A	Intermediate	Low
8.1.4	Lap Splice		N/A	Intermediate	Low

Table of Contents

PART 3 Repair and Modification of Printed Boards and Electronic Assemblies

Legends/Markings

Procedure	Description	Illustration	Product Class	Skill Level	Level of Conformance
2.7.1	Legend/Marking, Stamping Method		R, F, W, C	Intermediate	High
2.7.2	Legend/Marking, Hand Lettering Method		R, F, W, C	Intermediate	High
2.7.3	Legend/Marking, Stencil Method		R, F, W, C	Intermediate	High

Blisters and Delamination

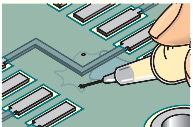
Procedure	Description	Illustration	Product Class	Skill Level	Level of Conformance
3.1	Delamination/Blister Repair, Injection Method		R	Advanced	High

Bow & Twist

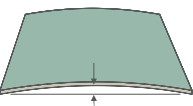
Procedure	Description	Illustration	Product Class	Skill Level	Level of Conformance
3.2	Bow and Twist Repair		R, W	Advanced	Medium

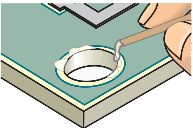
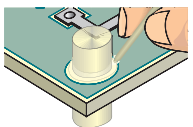

Hole Repair

Procedure	Description	Illustration	Product Class	Skill Level	Level of Conformance
3.3.1	Hole Repair, Epoxy Method		R, W	Advanced	High
3.3.2	Hole Repair, Transplant Method		R, W	Expert	High

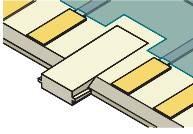
Key and Slot Repair

Procedure	Description	Illustration	Product Class	Skill Level	Level of Conformance
3.4.1	Key and Slot Repair, Epoxy Method		R, W	Advanced	High
3.4.2	Key and Slot Repair, Transplant Method		R, W	Expert	High



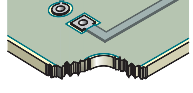

Base Material Repair

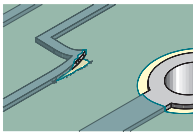
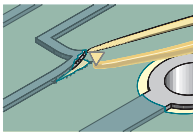
Procedure	Description	Illustration	Product Class	Skill Level	Level of Conformance
3.5.1	Base Material Repair, Epoxy Method		R, W	Advanced	High
3.5.2	Base Material Repair, Area Transplant Method		R, W	Expert	High
3.5.3	Base Material Repair, Edge Transplant Method		R, W	Expert	High

Lifted Conductors

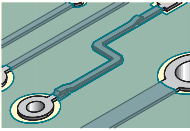
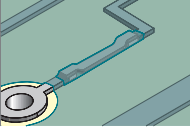
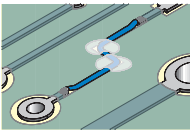
Procedure	Description	Illustration	Product Class	Skill Level	Level of Conformance
4.1.1	Lifted Conductor Repair, Epoxy Seal Method		R, F	Intermediate	Medium
4.1.2	Lifted Conductor Repair, Film Adhesive Method		R, F	Intermediate	High

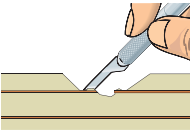
Conductor Repair

Procedure	Description	Illustration	Product Class	Skill Level	Level of Conformance
4.2.1A	Conductor Repair, Foil Jumper, Epoxy Method		R, F, C	Advanced	Medium
4.2.2	Conductor Repair, Foil Jumper, Film Adhesive Method		R, F, C	Advanced	High
4.2.3	Conductor Repair, Weld Method		R, F, C	Advanced	High
4.2.4	Conductor Repair, Surface Wire Method		R, F, C	Intermediate	Medium
4.2.5A	Conductor Repair Through Board Wire Method		R	Advanced	Medium
4.2.6	Conductor Repair/Modification, Conductive Ink Method		R, F, C	Expert	Medium
4.2.7	Conductor Repair, Inner Layer Method		R, F	Expert	High

Conductor Cut

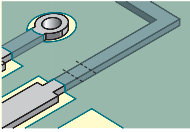
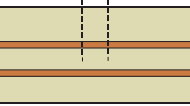
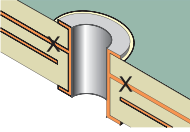
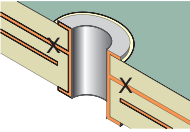
Procedure	Description	Illustration	Product Class	Skill Level	Level of Conformance
4.3.1A	Conductor Cut, Surface Conductors		R, F	Advanced	High
4.3.2	Conductor Cut, Inner Layer Conductors		R, F	Advanced	High
4.3.3	Deleting Inner Layer Connection at a Plated Hole, Drill Through Method		R, F	Advanced	High
4.3.4	Deleting Inner Layer Connection at a Plated Hole, Spoke Cut Method		R, F	Advanced	High

Lifted Land Repair

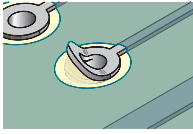
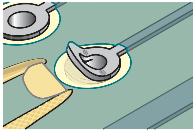
Procedure	Description	Illustration	Product Class	Skill Level	Level of Conformance
4.4.1	Lifted Land Repair, Epoxy Method		R, F	Advanced	Medium
4.4.2	Lifted Land Repair, Film Adhesive Method		R, F	Advanced	Medium

Land Repair

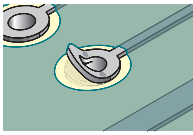
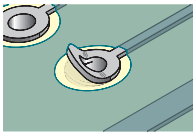
Procedure	Description	Illustration	Product Class	Skill Level	Level of Conformance
4.5.1	Land Repair, Epoxy Method		R, F	Advanced	Medium
4.5.2	Land Repair, Film Adhesive Method		R, F	Advanced	High

Edge Contact Repair

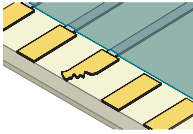
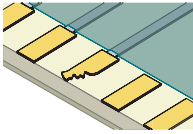
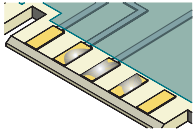
Procedure	Description	Illustration	Product Class	Skill Level	Level of Conformance
4.6.1	Edge Contact Repair, Epoxy Method		R, F, W, C	Advanced	Medium
4.6.2	Edge Contact Repair, Film Adhesive Method		R, F, W, C	Advanced	High
4.6.3	Edge Contact Repair, Plating Method		R, F, W, C	Advanced	High

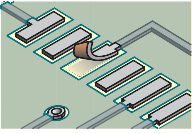
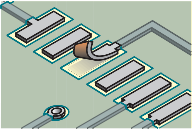

Surface Mount Pad Repair

Procedure	Description	Illustration	Product Class	Skill Level	Level of Conformance
4.7.1	Surface Mount Pad Repair, Epoxy Method		R, F, C	Advanced	Medium
4.7.2	Surface Mount Pad Repair, Film Adhesive Method		R, F, C	Advanced	High

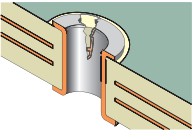
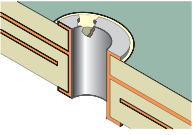
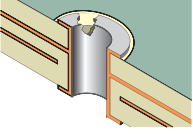
Plated Hole Repair

Procedure	Description	Illustration	Product Class	Skill Level	Level of Conformance
5.1	Plated Hole Repair, No Inner Layer Connection		R, F, W	Intermediate	High
5.2	Plated Hole Repair, Double Wall Method		R, F, W	Advanced	Medium
5.3	Plated Hole Repair, Inner Layer Connection		R	Expert	Medium

Jumpers

Procedure	Description	Illustration	Product Class	Skill Level	Level of Conformance
6.1	Jumper Wires		R, F, W, C	Intermediate	N/A
6.2.1	Jumper Wires, BGA Components, Foil Jumper Method		R, F	Expert	Medium
6.2.2	Jumper Wires, BGA Components, Through Board Method		R, F	Expert	High

Component Additions

Procedure	Description	Illustration	Product Class	Skill Level	Level of Conformance
6.3	Component Modifications and Additions		R, F, W, C	Advanced	N/A

Flexible Conductor Repair

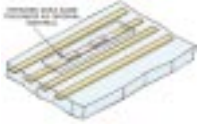
Procedure	Description	Illustration	Product Class	Skill Level	Level of Conformance
7.1.1	Flexible Conductor Repair		F	Expert	Medium

General Information and Common Procedures

1 General

1.1 Scope This document covers procedures for repairing and reworking printed board assemblies. It is an aggregate of information collected, integrated and assembled by the Repairability Subcommittee (7-34) of the Product Assurance Committee of the IPC.

1.2 Purpose This document prescribes the procedural requirements, tools and materials and methods to be used in the modification, rework, repair, overhaul or restoration of electronic products. Although this document is based in large part on the Product Class Definitions of ANSI/J-STD-001, this document should be considered applicable to any type of electronic equipment. When invoked by contract as the controlling document for the modification, rework, repair, overhaul or restoration of products, the requirements flowdown apply.

IPC has identified the most common equipment and process in order to affect a specific repair or rework. It is possible that alternate equipment and processes can be used to make the same repair. If alternate equipment is used, it is up to the user to determine that the resultant assembly is good and undamaged.

1.2.1 Definition of Requirements The words *must* and *shall* have no special meaning beyond that commonly used in other IPC standards.

1.2.2 Requirements Flowdown The applicable requirements of this document must be imposed by each manufacturer or supplier on all applicable subcontracts and purchase orders. The manufacturer or supplier must not impose or allow any variation from these requirements on subcontracts or purchase orders other than those that have been approved by the user. Unless otherwise specified, the requirements of this document are not imposed on the procurement of off the shelf assemblies or subassemblies. However, the manufacturer of these items may comply as deemed appropriate.

1.3 Background Today's PC boards are more complex and microminiaturized than ever before. Despite this, they can be successfully modified, reworked or repaired if the proper techniques are followed. This manual is designed to help you repair, rework and modify PC boards reliably. The procedures in this document have been obtained from end product assemblers, printed board manufacturers and end

product users who recognized the need for documenting commonly used rework, repair and modification techniques. These techniques have, in general, been proven to be acceptable for the class of product indicated through testing and extended field functionality. Procedures contained herein were submitted for inclusion by commercial and military organizations too numerous to list individually. The Repairability Subcommittee has, where appropriate, revised procedures to reflect improvements.

Rework completed satisfactorily will meet the original specification and requirements of IPC-A-600 and IPC-A-610. But, by definition, modifications and repairs do not comply with the initial design or fabrication criteria. For modification and repair, the user must recognize that the criteria in IPC-A-600 Acceptability of Printed Boards and IPC-A-610 Acceptability of Printed Board Assemblies are not necessarily applicable to the procedures herein. Modifications and repairs should not compensate for the lack of proper processes and quality controls. Ultimate cost effectiveness is achieved using appropriate design, fabrication and assembly techniques that minimize the need for modification and repair.

1.4 Controls Although modification, rework and repair procedures may be very similar, the control of such procedures may not be the same, due to the conditions and objectives involved.

1. *Modification*

The revision of the functional capability of a product in order to satisfy new acceptance criteria.

Modifications are usually required to incorporate design changes which can be controlled by drawings, change orders, etc. Modifications should only be performed when specifically authorized and described in detail on controlled documentation.

2. *Rework*

The act of reprocessing non-complying articles, through the use of original or equivalent processing, in a manner that assures full compliance of the article with applicable drawings or specifications.

3. *Repair*

The act of restoring the functional capability of a defective article in a manner that precludes compliance of the article with applicable drawings or specifications.